

A L F A

A L L E G R O

ALFA

SCHEDA TECNICA / TECHNICAL SPECIFICATION

MISURE / DIMENSIONS

FORNO A LEGNA

ALLEGRO TOP

FXALLE-LROA-T

rosso 

FXALLE-LGIA-T

giallo 

A	118 cm / 46,4 in
B	102 cm / 40 in
C	145 cm / 57,5 in
D	59 cm / 23,2 in
E	19 cm / 7,4 in
F	18 cm / 7 in
G	60 cm / 23,8 in

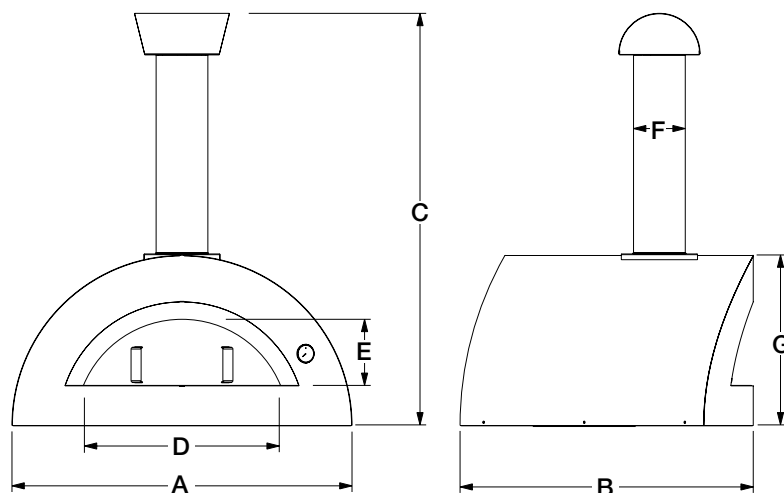

conforme a UNI 10474 e EN 13229
UNI 10474 and EN 13229 compliant

CARATTERISTICHE TECNICHE / TECHNICAL DETAILS

Peso <i>Weight</i>	170 kg 375 lbs	Materiali utilizzati <i>Used material</i>	lamiera ferro, acciaio inox, fibra ceramica iron sheet, stainless steel, ceramic fiber
Area piano forno <i>Oven floor area</i>	0,7 m ² 7,5 ft ²	Tipo di refrattario <i>Type of refractory</i>	Tavella silico-alluminoso Alumina silicate bricks
Dim. piano forno <i>Oven floor dim.</i>	100 x 70 cm 39,3 x 27,5 in	Combustibile consigliato <i>Recommended fuel</i>	Ciocchi diam. Max 5 cm, potature Max 1,9 In diam. logs, trimmings
Minuti per scaldare <i>Heating time (min)</i>	20	Carica nominale <i>Rated charge</i>	8,3 kg/h 18,3 Lbs/h
N° pizze alla volta <i>Pizza capacity</i>	5	Tiraggio minimo <i>Minimum flue draught</i>	11 Pa
Infornata di pane <i>Bread capacity</i>	5 kg 11 lbs	Flusso volumetrico fumi <i>Flue smokes mass flow</i>	49,6 g/s
Temperatura massima <i>Max oven temperature</i>	500°C 1000°F	Emissioni CO al 13% O₂ <i>CO emission at 13% O₂</i>	0,35% 4444 mg/Nm ³
Consumo medio <i>Average fuel consumption</i>	5 kg/h 11 lbs/h	Temperatura fumi <i>Smoke temperature</i>	387°C 728°F

MONTAGGIO E COMPONENTI / ASSEMBLY AND PARTS LIST

CODICE	N°	DESCRIZIONE
a	S6PZ_01_026	1 Comignolo
b	TL_180_750_SAT	1 Canna fumaria
c	6PZ_01_027	1 Flangia
d	CMB-01-032	1 Cupola camera forno
e	RRA-3020	5 Piano refrattario (30x20)cm
e	RRA-4020	5 Piano refrattario (40x20)cm
f	S6PZ_01_017	1 Davanzale inox
g	S6PZ_01_021	2 Sportello inox
h	CRT-01-0291-G	1 Carter esterno giallo per forno allegro
h	CRT-01-029-R	1 Carter esterno rosso per forno allegro
i	YT63-190	1 Termometro
j	CMB-01-033	1 Vasca camera forno
l	FCGSB602515	8 SIPOREX 1030x700x100mm
l	FCGSB602515	2 SIPOREX 1030x600x100mm

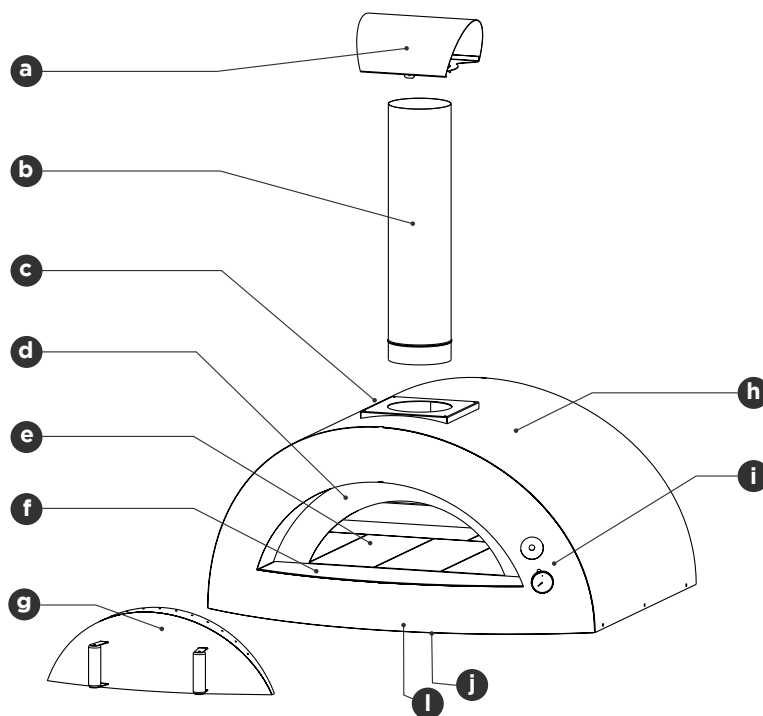

ALFA

FORNO A LEGNA

ALLEGRO

FXALLE-LROA

rosso 

FXALLE-LGIA

giallo 

conforme a UNI 10474 e EN 13229
UNI 10474 and EN 13229 compliant

SCHEDA TECNICA / TECHNICAL SPECIFICATION

MISURE / DIMENSIONS

A	118 cm / 46,4 in
B	102 cm / 40 in
C	225 cm / 88,6 in
D	59 cm / 23,2 in
E	19 cm / 7,4 in
F	18 cm / 7 in
G	95 cm / 37,4 in
H	70 cm / 27,5 in

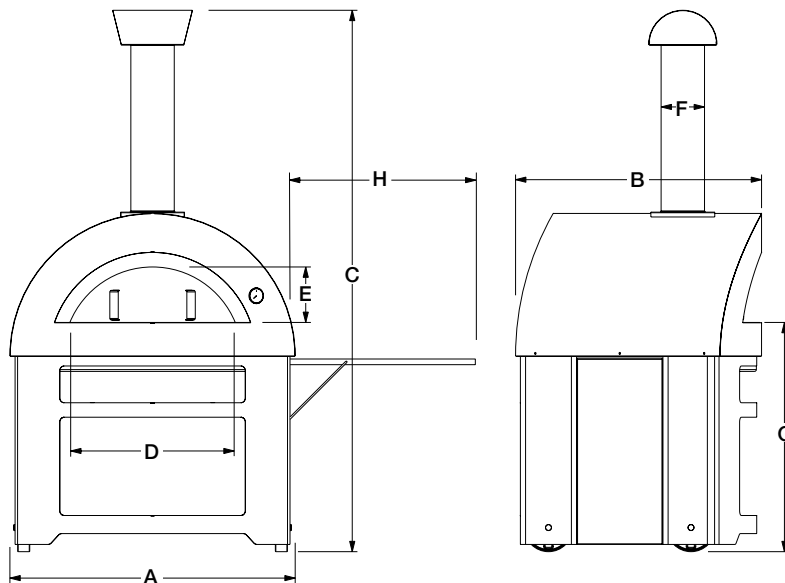

CARATTERISTICHE TECNICHE / TECHNICAL DETAILS

Peso <i>Weight</i>	245 kg 540 lbs	Materiali utilizzati <i>Used material</i>	lamiera ferro, acciaio inox, fibra ceramica iron sheet, stainless steel, ceramic fiber
Area piano forno <i>Oven floor area</i>	0,7 m ² 7,5 ft ²	Tipo di refrattario <i>Type of refractory</i>	Tavella silico-alluminoso Alumina silicate bricks
Dim. piano forno <i>Oven floor dim.</i>	100 x 70 cm 39,3 x 27,5 in	Combustibile consigliato <i>Recommended fuel</i>	Ciocchi diam. Max 5 cm, potature Max 1,9 In diam. logs, trimmings
Minuti per scaldare <i>Heating time (min)</i>	20	Carica nominale <i>Rated charge</i>	8,3 kg/h 18,3 Lbs/h
N° pizze alla volta <i>Pizza capacity</i>	5	Tiraggio minimo <i>Minimum flue draught</i>	11 Pa
Infornata di pane <i>Bread capacity</i>	5 kg 11 lbs	Flusso volumetrico fumi <i>Flue smokes mass flow</i>	49,6 g/s
Temperatura massima <i>Max oven temperature</i>	500°C 1000°F	Emissioni CO al 13% O₂ <i>CO emission at 13% O₂</i>	0,35% 4444 mg/Nm ³
Consumo medio <i>Average fuel consumption</i>	5 kg/h 11 lbs/h	Temperatura fumi <i>Smoke temperature</i>	387°C 728°F

MONTAGGIO E COMPONENTI / ASSEMBLY AND PARTS LIST

CODICE	N°	DESCRIZIONE
a	S6PZ_01_026	1 Comignolo
b	TL_180_750_SAT	1 Canna fumaria
c	6PZ_01_027	1 Flangia
d	S6PZ_01_002	1 Camera forno
e	RRA-3020	5 Piano refrattario (30x20)cm
e	RRA-4020	5 Piano refrattario (40x20)cm
f	S6PZ_01_017	1 Davanzale inox
g	S6PZ_01_021	2 Sportello inox
h	S6PZ_01_038-NE	1 Ripiani laterali
i	S6PZ_01_011-G	1 Carter esterno giallo per forno allegro
i	S6PZ_01_011-R	1 Carter esterno rosso per forno allegro
j	YT63-190	1 Termometro
k	S6PZ_01_028-NE	1 Base forno allegro
l	OPGA200020	1 Ruote
m	SFRU-01-100	2 Ferma ruota
n	CMB-01-033	1 Vasca camera forno
o		1 SIPOREX 1030x700x100mm

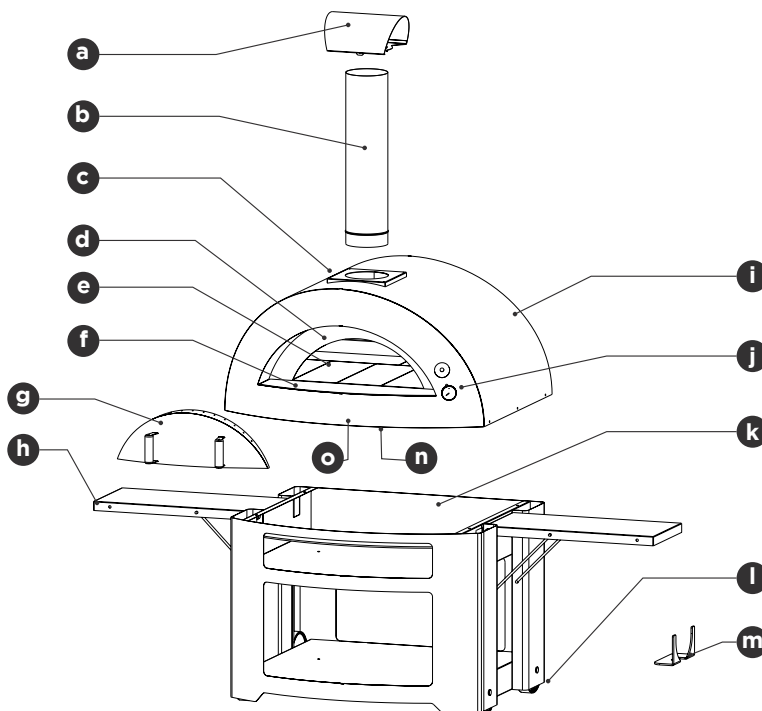

ALFA REFRATTARI S.R.L.

via Osteria della Fontana 63, 03012 Anagni (FR), Italy

web site: www.alfaforni.com - www.alfaovens.com
e-mail: info@alfaforni.com

tel: +39 0775.7821 - fax: +39 0775.782218